

34-214C C-Yoke Compression Riveter

All parts shown on this list are interchangeable with like items offered by Chicago Pneumatic, Deutsch APT, and several other makes.

Model Number	Capacity Cold Rivet Diameter		Standard Yoke Dimensions			Max. Force @ 90 PSI	Set Holding Plunger		Net Weight	Overall Length	Air Inlet Thread Size	Gap	Set Hole Size
	Alum.	Steel	Reach	Closed Height	C-Yoke Part No.		Maximum Travel	Stroke @ Max. Force					
34-214C	1/8"	3/32"	1-1/2"	11/16"	64-C1	3300 lbs	9/16"	Final 1/16"	4.5 lbs	10-5/16"	1/4"	1-1/4"	3/16"

Note: The table above details the included C-Yoke which is suitable for most applications. USATCO also offers many other C-Yokes designed for more specific applications, please inquire. USATCO can also fabricate custom yoke designs, please submit a blueprint or sample of your riveting problem for quote.

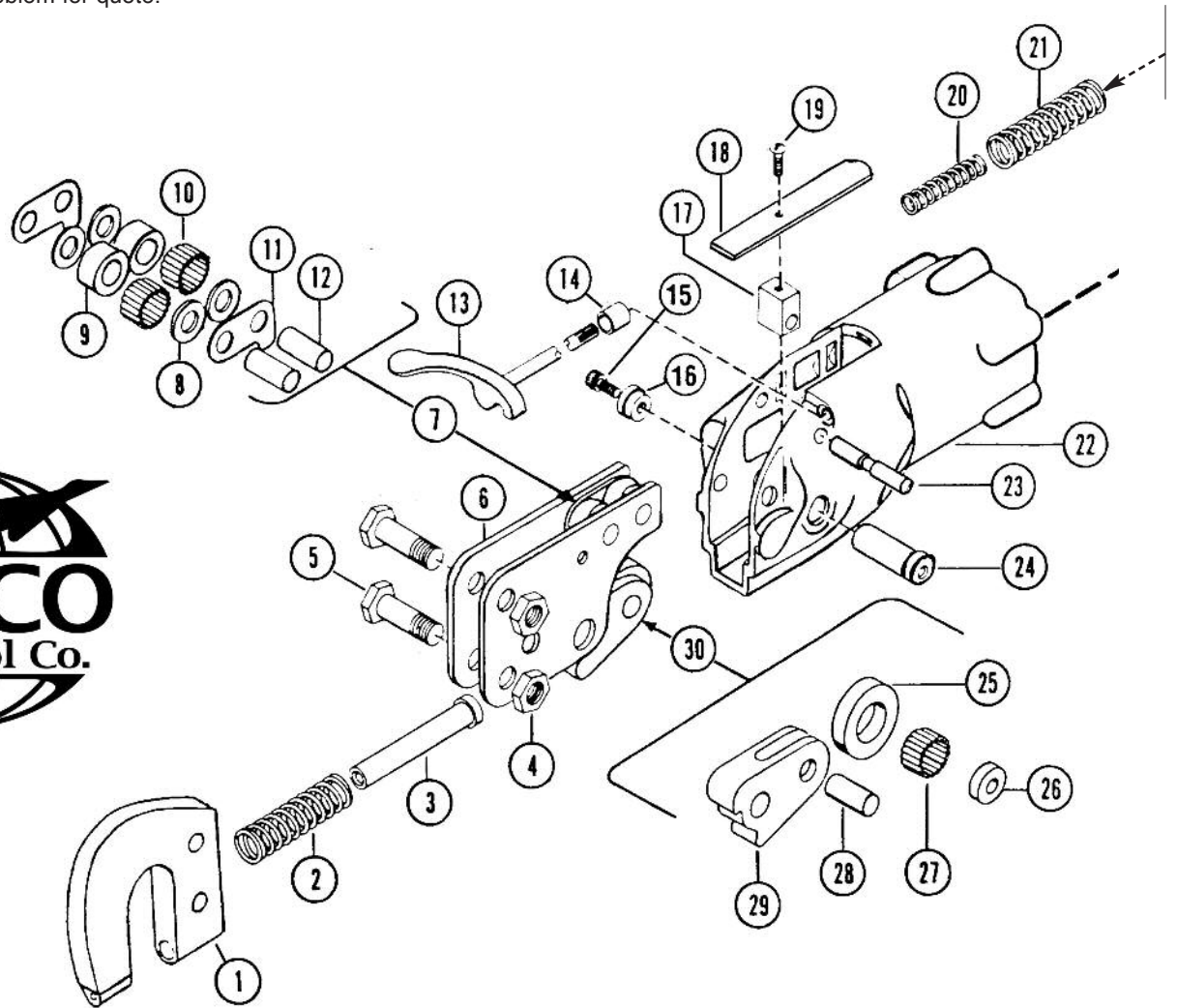

USATCO U.S. Air Tool Company, Inc.

Eastern Division60 Fleetwood Ct., Ronkonkoma, NY 11779-6907 tel: (631) 471-3300 fax: (631) 471-3308
 Western Division1219 W. Mahalo Place, Rancho Dominguez, CA 90220-5446 tel: (310) 632-5400 fax: (310) 632-3900

Many new features built into this rugged, well balanced compression riveter ensure a longer, more trouble free life than other compression riveters of it's size and weight.

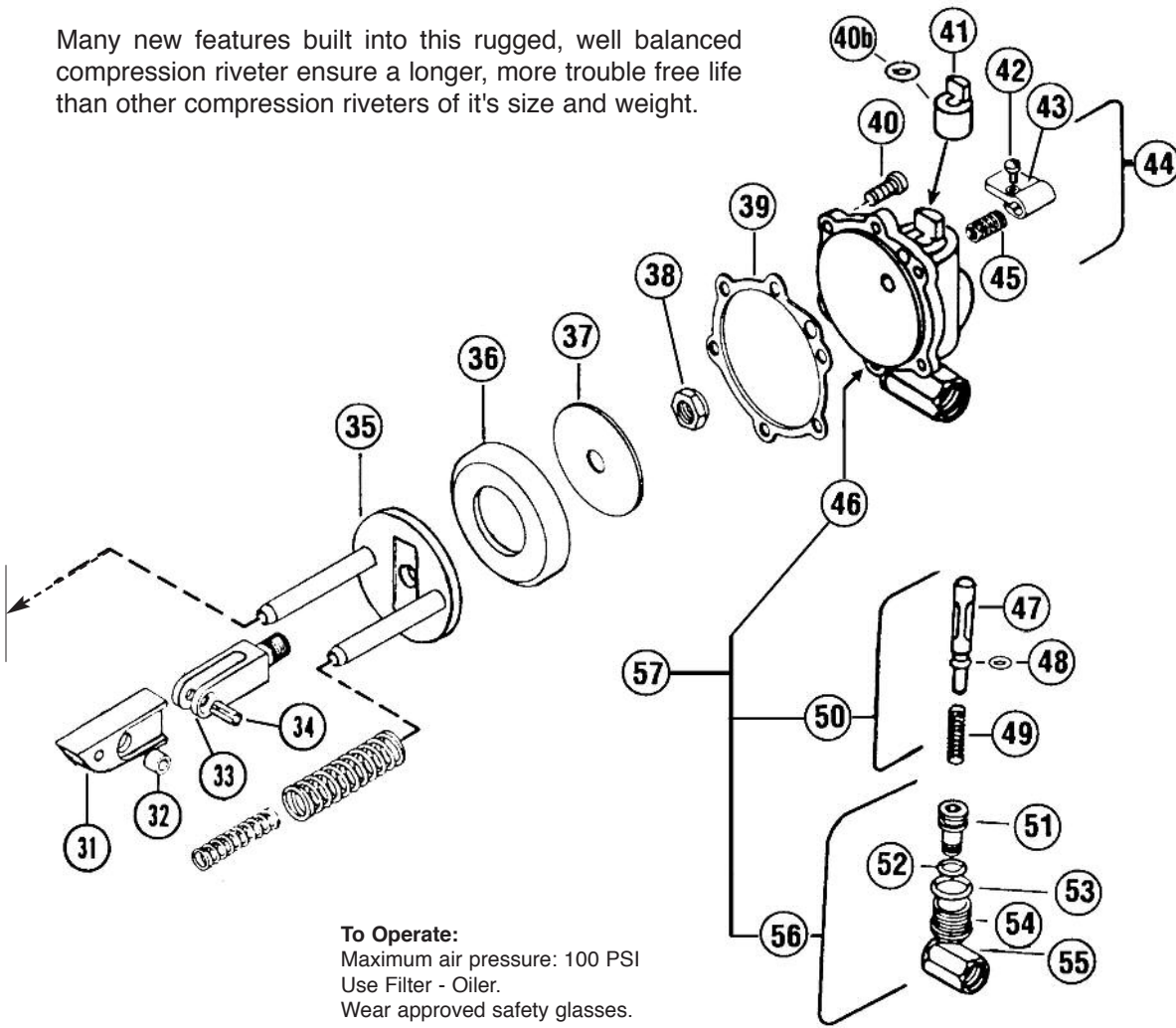

To Operate:
 Maximum air pressure: 100 PSI
 Use Filter - Oiler.
 Wear approved safety glasses.

Rivet Sets Kit

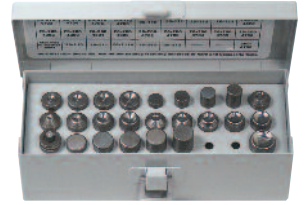

53-26

Virtually all the tooling you will need for your squeezer. Assorted cupped, flush, soft blanks and spacer shims. 31 Pieces, Metal case included.

Floor Stand



Includes:

- Stand
- Foot Control Assembly
- Conversion Head

37-12

Available with or without tool.

C-Yokes for the 34-214C Rivet Squeezer

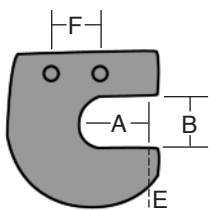

64-C1 Reach 'A': 1-7/16" Gap 'B': 1-1/4"
 Set Hole 'E': .187" Mount Spacing 'F': 1-5/16"

64-C200 Reach 'A': 2" Gap 'B': 1-1/4"
 Set Hole 'E': .187" Mount Spacing 'F': 1-5/16"

64-C300 Reach 'A': 3" Gap 'B': 1-1/4"
 Set Hole 'E': .187" Mount Spacing 'F': 1-5/16"

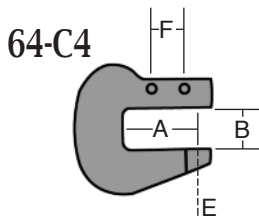

64-C4 Reach 'A': 3-1/2"
 Gap 'B': 1-3/4"
 Set Hole 'E': .187"
 Mount Spacing 'F': 1-5/16"

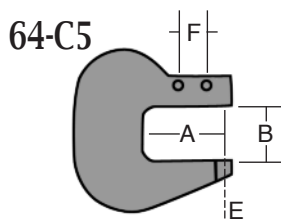

64-C5 Reach 'A': 4-1/8"
 Gap 'B': 2-1/2"
 Set Hole 'E': .187"
 Mount Spacing 'F': 1-5/16"

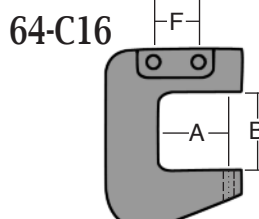

64-C16 Reach 'A': 2"
 Gap 'B': 2"
 Mount Spacing 'F': 1.312"
With Adj. Threaded Adapter

Adjustable Set Holder



97798

Replaces the standard rigid set holder and eliminates the need to shim the dies / sets with washers.

Bench Mount Riveter

34-720CBR2
 Please Inquire



Index Number	Part Number	Part Description	Amount Required
1	64-C1	C-Yoke, Standard (other configurations available)	1
2	38-540	Return Spring	1
3	38-539	Set Holder, Standard 2-9/16" O.A.L. with 3/16" Set Hole (other lengths avail.)	1
4	38-415	Nut	2
5	38-541	Bolt	2
6	38-494	Plate	2
7	38-554	Roller Bearing Assembly (includes index numbers 8, 9, 10, 11 & 12)	1
8	38-472	Washer	4
9	38-469	Roller Bearing	2
10	38-626	Needle Bearing (2 Sets)	20 / 20
11	38-498	Guide	2
12	38-470	Roller Bearing Shaft	2
13	38-795	Throttle Valve Lever	1
14	38-572	Spacer	1
15	38-369	Screw	1
16	38-537	Cap, Shaft	1
17	38-496	Spacer	1
18	38-495	Roller Bearing Guard	1
19	38-456	Screw	1
20	38-467	Inner Spring	2
21	38-468	Outer Spring	2
22	38-589	Cylinder	1
23	38-497	Pin	1
24	38-536	Shaft	1
25	38-533	Roller Bearings	1
26	38-534	Inner Bearing Roller	1
27	38-627	Needle Bearings	25
28	38-535	Shaft	1
29	38-532	Lever	1
30	38-553	Lever Assembly (includes index numbers 25, 26, 27, 28 & 29)	1
31	38-493	Wedge	1
32	38-465	Spacer	1
33	38-462	Piston Shaft Fork	1
34	38-466	Roll Pin	1
35	38-438	Piston	1
36	38-460	Cup Leather	1
37	38-461	Plate	1
38	38-463	Locknut	1
39	38-483	Gasket	1
40	38-410	Screw	6
40b	38-5183	"O" Ring (-010)	1
41	38-6309	Bushing	1
42	38-628	Screw	1
43	38-901	Throttle Lever	1
44	38-944	Throttle Lever Assembly (includes index numbers 42 & 43)	1
45	38-200	Spring	1
46	38-940	Cylinder Head (includes index numbers 40b & 41)	1
47	38-6298	Throttle Valve, Standard	1
48	38-566	"O" Ring (-008)	1
49	38-3577	Spring	1
50	38-6346	Valve Assembly (includes index numbers 47, 48 & 49)	1
51	38-1585	Air Inlet Swivel	1
52	38-491	"O" Ring (-012)	1
53	38-488	"O" Ring (-014)	1
54	38-499	Nut	1
55	38-522	Elbow (90° - 1/4 pipe)	1
56	38-2436	Air Inlet Swivel Complete (includes index numbers 51, 52, 53, 54 & 55)	1
57	38-943	Cylinder Head Assembly Complete (includes index numbers 46, 50 & 56)	1
599	38-1607	Cylinder Head, Valveless: Use with foot or hand valve control, usually with floor stand or bench mounting. (not shown)	1



USATCO U.S. Air Tool Company, Inc.

Eastern Division60 Fleetwood Ct., Ronkonkoma, NY 11779-6907 tel: (631) 471-3300 fax: (631) 471-3308
Western Division1219 W. Mahalo Place, Rancho Dominguez, CA 90220-5446 tel: (310) 632-5400 fax: (310) 632-3900

34-214C

C-Yoke Compression Riveter Parts List



- CE approved and certified.
- Quiet, easy operation.
- Clamping force exceeds federal specs.
- New, larger capacity high-force models now available, please inquire.
- Good balance, easy handling.
- Safety approved throttle lever.
- 90° swiveling air inlet.
- Tool steel roller bearings and shafts.
- Operates with little or no oil.



Model No. **34-214C** Shown

Note: Operate this tool at 90 PSI (6.2 bar).

Toll Free Nationwide & Canada: **800-645-8180**

USATCO\U.S. AIR TOOL COMPANY, INC. www.USATCO.COM NEW YORK • CALIFORNIA

Rev0515